



Discovery

Semi-Micro and Analytical Balances

The Professional's Choice For Analytical Applications!

The NEW Ohaus Discovery series of semi-micro and analytical balances combine unmatched weighing performance with Ohaus' innovative SmarText™ software, making it extremely reliable and easy-to-use. The Discovery features durable glass and steel construction and together with advanced AutoCal™ internal calibration make it the best performing balance in its class:

- **Highest Performance** with repeatability and linearity performance that's 2x better than most balances in its class
- **SmarText™ Software** utilizes text prompts to guide users through application use and balance setup
- **Advanced AutoCal™** automatic internal calibration ensures accurate weighing

The Ohaus Discovery series features four analytical models with capacities up to 310g by 0.1mg with a FineRange™ model that offers 10 microgram readability. Discovery is perfect for university research, pharmaceutical research and drug discovery, and general lab applications.

Discovery *Semi-Micro and Analytical Balances*

Highest Performance

Discovery's repeatability and linearity performance is 2x better than most semi-micro balances in its class. Glass and steel construction resists the effects of static and corrosion increasing balance stability and accuracy, as well as extending product life.



SmarText™ Software Brings Man and Machine Together

SmarText™ is Ohaus' easy to use balance software that utilizes text prompts to guide users through application use and balance setup. Delivered through a 2-line backlit LCD and clearly marked buttons, SmarText™ tells you what is going on and what you have to do next.



Utilizing the 2-line LCD, SmarText™ simultaneously displays weight and application-specific information such as percent or count. At the touch of the Function button, SmarText™ will display application reference information such as the average piece weight (APW).

Advanced AutoCal™ Automatic Internal Calibration

To minimize weighing errors and ensure accurate measurements, AutoCal™ utilizes two internal weights to perform a linear calibration.



AutoCal™ internal calibration system automatically calibrates the balance when it senses a temperature change significant enough to affect the weighing accuracy.

Ohaus Discovery Application Modes

Statistics Mode

Statistics are used when it is desired to compare a number of samples and examine the relative deviation of the samples along with other statistical data. A minimum of three samples are required in this program. Statistics contains menu options which include: number of samples, maximum, minimum, difference, sum, mean, standard deviation, relative deviation, auto sample, and auto print.

In addition to standard weighing, statistical data can be provided for Animal/Dynamic Weighing and Checkweighing measurements.



Density Mode

Discovery provides users with four methods of density determination to choose from depending on their need. They are:

1. User can determine density for solids more dense than water
2. User can determine density for solids less dense than water
3. User can determine density for liquid density (sinker needed – not included)
4. User can determine density for Porous material (impregnated with oil).



After entering a couple of parameters into the balance, the built in density table, and mass measurement of the balance take over to provide rapid and accurate density results, with no manual calculations needed.



Pipette Calibration Mode

Pipette calibration checks the accuracy and precision values of pipettes by weight analysis. The Discovery DV215CD 0.01mg semi-micro balance is recommended for maximum



accuracy. To calibrate a pipette, the user will select the type of liquid to be used in the pipette (normally water), barometric pressure, nominal value, and unit of measure of the pipette. The balance will do the rest. The Discovery will accept an alternate liquid's density in g/cc at current room temperature as well.

Discovery Semi-Micro and Analytical Balances

Ohaus Discovery Application Modes

Percent Weighing Mode

This mode allows the user to display the weight of a sample as a percentage of a reference weight useful in sieving applications, reagent weighing, moisture determination, and other types of ingredient mixing.

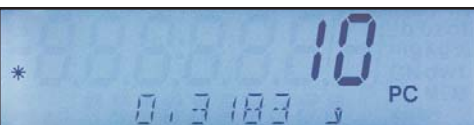

Parts Counting Mode

Parts counting mode is useful when counting pills, or parts that have a consistent, but low nominal mass. This mode allows the user to count based on a calculated piece weight. The optimization feature improves counting accuracy by automatically re-calculating the piece weight as parts are added.

Check Weighing Mode

This mode allows the user to check the weight of a sample against preset target parameters such as underweight and overweight.



Dynamic Weighing Mode

Dynamic weighing can be used when either a rough environment is encountered such as on a ship, or when in a location that may not have ideal conditions. In addition, this mode allows the user to weigh moving objects such as animals, insects or other moving specimens. Dynamic weighing averages out weight readings over a period of time and displays the results until cleared.

Totalization Mode

This mode allows the user to sum a series of sample weights that can be greater than the capacity of the balance. Totalization is helpful when adding the masses of several samples together without the need for a calculator.



High Point Mode

High Point can be used when analyzing batches or lots, or for quality checking of random samples. When in High Point mode, the balance will save only the highest weight value from a series of weighings.

Key Features:

Multiple Weighing Units

Discovery features multiple weighing units including a user-defined custom unit for use in unique weighing applications.

Environmental Settings

When working in harsh environments, users can adjust Discovery's environmental settings to compensate for vibrations and other disturbances.

Connectivity

Discovery comes with an included RS232 interface and provides full GLP/GMP data output.



Up-Front Level Indicator

Discovery has been designed with an up-front level indicator eliminating the need to look behind the balance during the leveling process. A quick glance at the up-front level indicator helps to ensure that the balance is level prior to each use.



Weigh-Below Hook

Discovery's integral weigh-below hook allows density determination or calculating the specific gravity of samples.

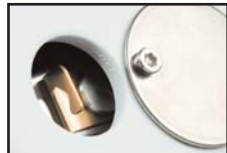

Easy to View Display

Discovery features a 2-line alphanumeric LCD with brilliant backlight.

Easy to Use Keypad

Four-button keypad with dedicated YES, NO, BACK and EXIT functions simplify menu navigation and balance set-up. Dedicated left and right tare buttons provide ambidextrous taring.

Easy to Clean

Discovery's stainless steel platform and removable wind ring make it extremely easy to clean.



Outline Dimensional Drawings

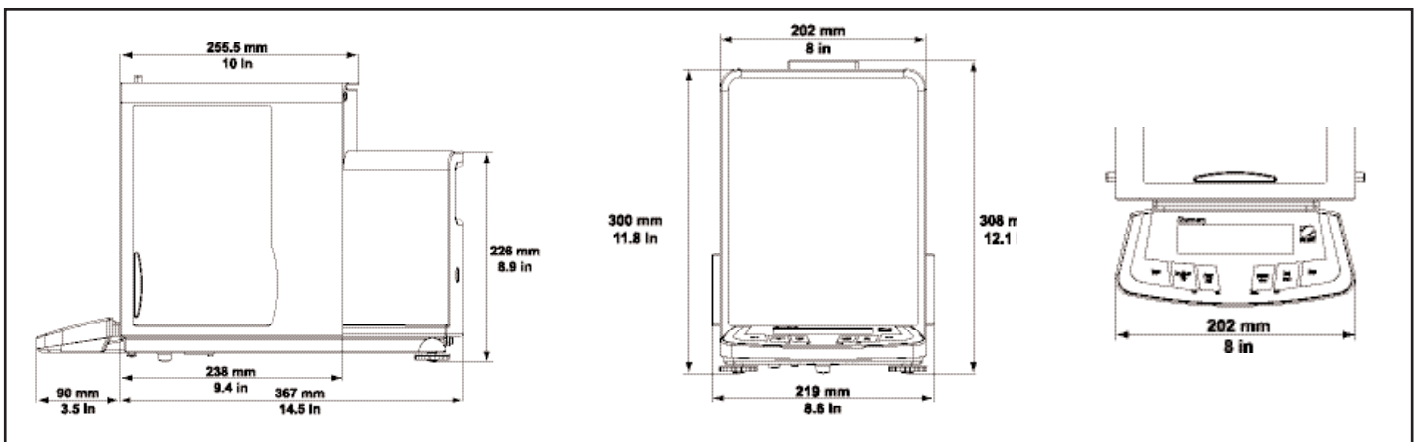

Discovery Semi-Micro and Analytical Balances

Specifications

Model	DV114C	DV214C	DV314C	DV215CD
Capacity (g)	110	210	310	81*/210
Readability (mg)	0.1	0.1	0.1	0.01*/0.1
Repeatability (Std.dev.) (mg)	0.1	0.1	0.2	0.02*/0.1
Linearity (mg)	±0.2		±0.5	±0.03*/0.2
Weighing Units	Milligram, Gram, Carat, Ounce, Ounce Troy, Grain, Pennyweight, Momme, Hong Kong Tael, Singapore Tael, Taiwan Tael, Custom			
Application Modes	Weighing, Parts Counting with Automatic Sample Recalibration, Percent Weighing, Checkweighing, Animal/Dynamic Weighing, Gross/Net/Tare Weighing, Totalization, High Point, Density, Statistics, Pipette Calibration			
Features	Selectable Environmental Filters, RS232 Interface with full GLP/GMP Protocol, Easy to Clean Stainless Steel Platform, Windring and Glass & Steel Construction, Protective In-Use Cover, Integral Weigh Below Hook, Easy to Use Keypad, Up-Front Level Indicator			
Tare Range	To Capacity by Subtraction			
Stabilization Time (s)	4		8	12/5
Sensitivity Drift (10-30°C)	±2ppm/°C			
Operating Temp Range	10° to 40°C			
Calibration	Automatic internal, Pushbutton internal, Manual external			
Power Requirements	External Adapter, 100-120VAC 150mA, 220-240VAC 100mA, 50/60 Hz Plug configuration for US, Euro, UK, Japan & Australian			
Display Type	2-line Alphanumeric Backlit LCD Display			
Display Size (cm)	10 x 2.5			
Pan Size (Diameter) (cm)	9			
Height above pan (cm)	24			
Dimension WxHxD (cm)	20 x 30 x 45.7			
Net Weight (kg)	10.2			

*FineRange™

Other Standard Features and Equipment

Stability indicator, mechanical and software overload/underload protection, AC adapter, user selectable span calibration points, auto tare, auto shut-off, user selectable printing options, user selectable communications settings, user selectable data print options, user definable project and user ID's, software reset menu, software lockout menu

Approvals

CE, FCC, CUL_{US}, CSA_{US}, NRTL, OIML

Accessories	Ohaus Number
Impact printer, 42 column	SF42
RS232 cable, SF42 printer	21253677
SF42 printer paper (5 pack)	12101511
SF42 printer ribbon	12101512
RS232 cable, IBM 9 pin	80500525
RS232 cable, IBM 25 pin	80500524
Density determination kit	00223015
Storage Cover	00223147
Security device	00223150
Calibration Mass	Contact your Ohaus dealer for further informations

www.ohaus.com



ISO 9001:2000
Registered Quality Management System

Industry Leading Quality and Support

All Ohaus Discovery balances are manufactured under an ISO 9001:2000 Registered Quality Management System. Our rugged construction and stringent quality control have been hallmarks of all Ohaus products for nearly a century.

Avd. Sandnes
T.A. Elektronik AS
Gravarsveien 55
4306 Sandnes
Tlf.nr.: 51 66 65 17

Avd. Oslo
T.A. Elektronik AS
Trollåsveien 4
1414 Trollåsen
Tlf.nr.: 992 85 812

E-mail: post@taelektronikk.no
Web: www.taelektronikk.no
Support: 992 85 814
Faks: 51 67 10 07